

Evaporative Cooling Tower



CROSS FLOW SPLASH TYPE COOLING TOWER



SPLASH TYPE COUNTER FLOW COOLING TOWER



SPLASH TYPE CROSS FLOW COOLING TOWER



RENOVATE COOLING TOWER

Stay Cooling, Be Smart

www.renovate.net

TECHNICAL SPECIFICATIONS OF CROSS FLOW SPLASH TYPE (ETP) COOLING TOWER

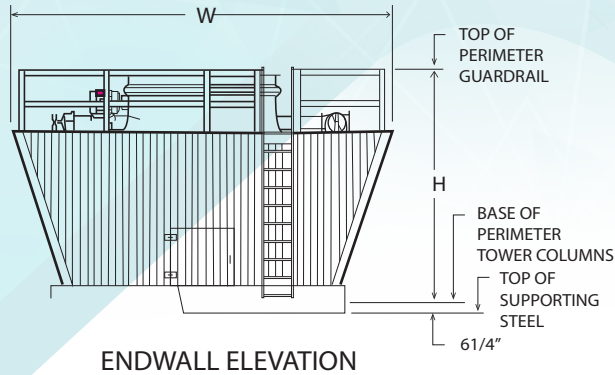
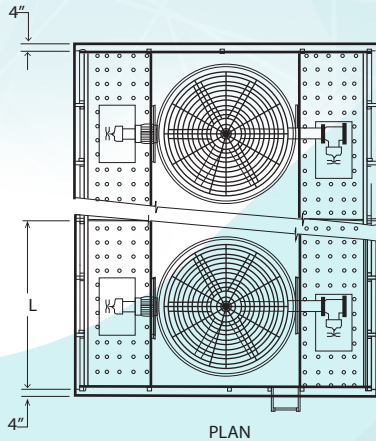

Design Condition
 Water flow rate = 390m³/h
 T_{in} = 37° C
 T_{out} = 32° C
 WBT = 29° C
 IRT = 3900 kcal/hour

MODEL	FLOW RATE	OVERALL DIMENSION					FAN ASSEMBLY				WEIGHT APPROX		PIPE CONNECTION					
		L	W	H1	H2	H3	FAN Ø	MOTER HP	FAN SPEED	DRIVE	DEAD KG	OPPERATING KG	I N LET	OUT LET	DRAIN	OVER D	AUTO E	QUICK F
RRTX-100	1300	1500	3560	2075	815	3550	1300X	2HP 4P	512	V-BELT DIRECT DRIVE	970	1950	140X2	125	50A	50A	25A	25A
	4HP 8P							750	5				5	2	2	1	1	
RRTX-125	1625	1500	3560	2075	815	3550	1300X1	3HP 4P	625	V-BELT DIRECT DRIVE	990	1970	140X2	125	50A	50A	25A	25A
	3HP 6P							750	5				5	2	2	1	1	
RRTX-150	1950	1800	3760	2075	915	3550	1500X1	5HP 4P	465	V-BELT DIRECT DRIVE	1110	2360	140X2	165	50A	50A	25A	25A
	117						3HP 8P	750	6				2	2	1	1		
RRTX-175	2275	1800	3760	2075	915	3550	1500X1	7.5HP 4P	557	V-BELT DIRECT DRIVE	1200	2460	140X2	165	50A	50A	25A	25A
	137						5HP 8P	750	6				2	2	1	1		
RRTX-200	2600	2100	3960	2075	915	3680	1700X1	7.5HP 4P	495	V-BELT DIRECT DRIVE	1400	2840	140X2	165	65A	65A	25AX2	40A
	156						5HP 10P	560	6				2.5	2.5	1X2	1.5		
RRTX-250	3250	2450	4260	2075	915	3720	2000X1	7.5HP 4P	450	V-BELT DIRECT DRIVE	1600	3510	140X2	200	65A	65A	25AX2	40A
	195						5HP 10P	560	8				2.5	1X2	1.5			
RRTX-300	3900	2450	4565	2075	1200	3935	2000X1	10HP 4P	475	V-BELT DIRECT DRIVE	1800	3700	165X2	200	80A	80A	25AX2	40A
	234						7.5HP 12P	480	8				3	3	1	1.5		
RRTX-350	5460	3150	5080	2075	1200	3935	2400X1	10 HP 4P	475	V-BELT DIRECT DRIVE	2000	4300	165X2	200	80A	80A	25AX2	40A
	273						7.5HP 12P	480	8				3	3	1X2	1.5		
RRTX-400	5220	3150	5630	2800	1200	4800	2400	15 HP 4P	475	V-BELT OR GEAR	2800	5800	165X2	250	80A	80A	25X2	50A
	312												10	3	3	1X2	2	
RRTX-500	6500	3700	6000	2800	1200	4800	3000	15 HP 4P	380	V-BELT OR GEAR	3500	7506	165X2	250	80A	80A	25X2	50A
	390												10	3	3	1X2	2	
RRTX-600	7800	4000	6650	2800	1200	4800	3200	20 HP 4P	340	V-BELT OR GEAR	4250	8100	165X2	250	80A	80	25X2	50A
	468												10	3	A	1X2	2	
RRTX-700	9160	4000	6650	3200	1200	5300	3200	20 HP	340	V-BELT OR GEAR	4800	9000	200X2	250	80A	80A	25X2	50A
	546												10	3	3	1X2	2	
RRTX-800	10400	4000	6650	3400	1200	5700	3200	25 HP	340	V-BELT OR GEAR	5200	11250	200X2	300	100A	100A	25AX2	65A
	625												12	4	4	1X2	2.5	
RRTX-1000	13000	4600	7000	4300	1200	5800	3600	30 HP	320	V-BELT OR GEAR	7600	15200	200X2	300	100A	100A	25AX2	65A
	780												12	4	4	1X2	2.5	

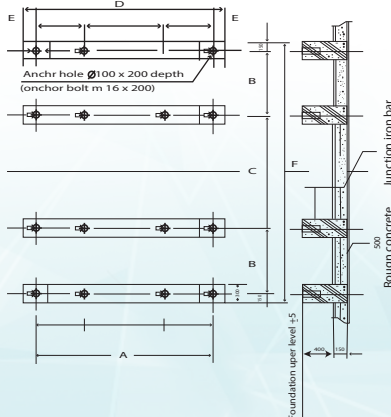

FOUNDATION (SINGLE CELL)						
MODEL	A	B	C	D	E	F
RRTX 100-125	1300	1115	1240	1600		3560
150-175	1600	1115	1440	1900		3760
200	1900	1115	1640	2200		4170
250	2250	1115	1940	2550		4470
300	2250	1310	1940	2950		4560
350	3050	1115	2750	3350		5280
400	2930	1375	2880	3230	900	5690
500	3500	1375	3160	3800	1050	6210
600	3800	1375	3700	4100	1150	6750
700	3800	1375	3700	4100	1150	6750
800	4400	1375	4000	4700	1250	7050
1000	4400	1375	4000	4700	1250	7050

• MULTIPLE CELL FOUNDATION & DIMENTION PLEASE CONTACT RENOVATE COOLINT TOWER ENGINEERING DEPARTMENT